

NOTICE OF PROPRIETARY RIGHTS: THIS DOCUMENT CONTAINS CONFIDENTIAL TECHNICAL DATA, INCLUDING TRADE SECRETS, PROPRIETARY TO TIMES MICROWAVE SYSTEMS. DISCLOSURE OF THIS DATA IS EXPRESSLY CONDITIONED UPON YOUR ASSENT THAT ITS USE IS LIMITED TO USE WITHIN YOUR COMPANY ONLY. ANY OTHER USE IS STRICTLY PROHIBITED WITHOUT THE PRIOR WRITTEN CONSENT OF TIMES MICROWAVE SYSTEMS.

SYM	REVISION DESCRIPTION	DFTM	DATE	APPD	DATE
-	RELEASED FOR PRODUCTION	J. C. L.	2/21/01	J. C. L.	2/21/01
A	UPDATED OUTLINE SKETCH	J. C. L.	5/12/04	J. C. L.	5/12/04
B	UPDATED TO NMH-D	J. C. L.	9/28/06	J. C. L.	9/28/06
C	CHANGED PER CDC #27801	D. J. H.	1/17/08	J. D. B.	1/21/08

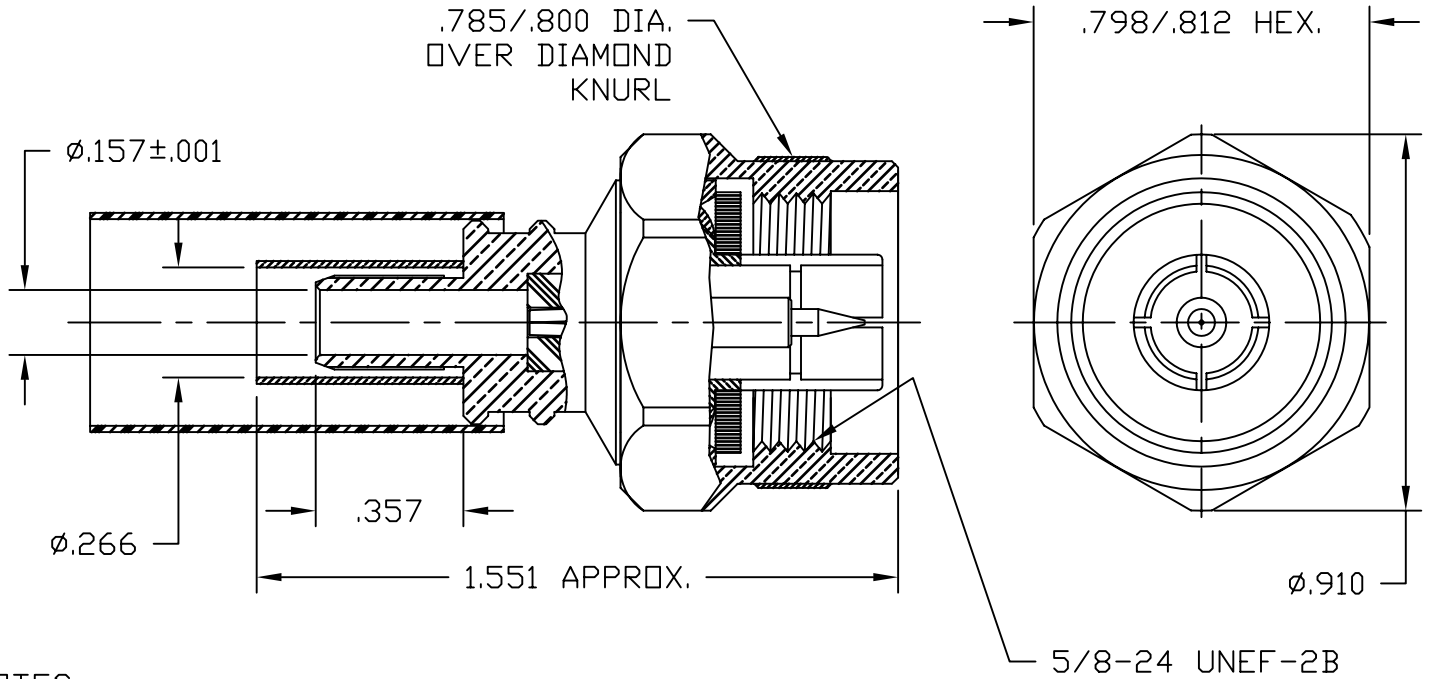

NOTES:

1. ASSEMBLED CONNECTOR INTERFACE IS DESIGNED IN ACCORDANCE WITH MIL-STD-348.
2. MATERIAL: SHRINK SLEEVE - SHRINKABLE POLYOLEFIN PER MIL-I-23053/5
 CONTACT - BERYLLIUM COPPER PER ASTM B196
 SNAP RING - PHOSPHOR BRONZE PER QQ-P-330
 CRIMP SLEEVE - D.H.P. COPPER CDA ALLOY 122
 GASKET - SILICONE RUBBER PER ZZ-R-765
 INSULATOR - TEFLON PER ASTM D1710
 ALL OTHER METAL PARTS - BRASS PER ASTM B16
3. FINISHES: CONTACT - GOLD PLATE PER MIL-G-45204 (30 microinches)
 CRIMP SLEEVE - SULFAMATE NICKEL PER MIL-P-27418
 ALL OTHER METAL PARTS - ALBALDY PLATE
4. RECOMMENDED CRIMPING TOOL: M22520/5-19, CLOSURE A, (.255 HEX DIE)

MATERIAL:	UNLESS OTHERWISE SPECIFIED		DFTM. J. C. L.	TIMES MICROWAVE SYSTEMS
	ALL DIMENSIONS ARE IN INCHES MACHINED SURFACES FINISH 32 RMS MAX. REMOVE ALL BURRS .005 MAX. BREAK MACHINE CORNERS .005 MAX. FILLET R. TOLERANCES ON DECIMALS .XX ± .03 .XXX ± .005 ANGLES ± 1° FRACTIONS ± 1/32		DATE 2/21/01	
USED ON: -			CHKD. J. C. L.	"N" MALE CRIMP FOR LMR-240 CABLE
			DATE 2/21/01	
SCALE: NONE	DWG. SIZE A	DO NOT SCALE DRAWING	APPD. J. C. L.	1 of 1 SD3190-1127
			DATE 2/21/01	
		CODE IDENT 68999		REV C