

TOLERANCES	
INCHES	MILLIMETERS
.00 = ±.01	.0 = ±.25
.000 = ±.004	.00 = ±.10
DRAWN: MJD	APPROVED: EMM
DATE: 01/01/14	DATE: 01/01/14

117X83X21

MODEL NO.
GFO-2-0825

SPLITTER 2 VIE

REV	DESCRIPTION	BY	DATE

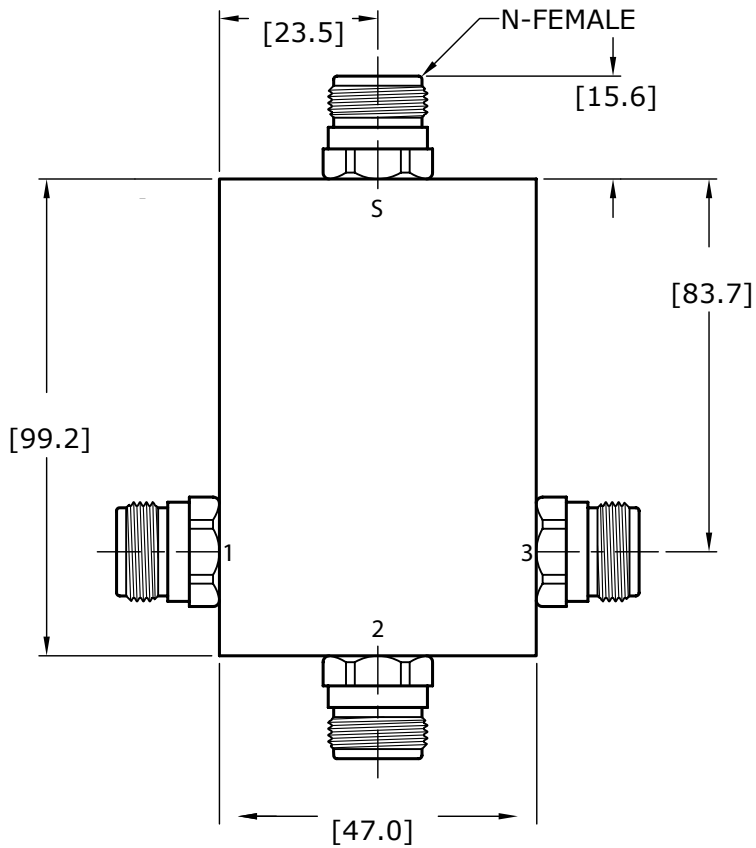
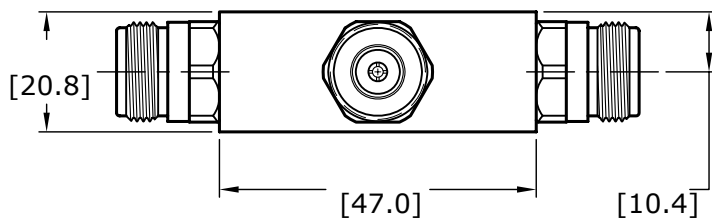

TOLERANCES	
INCHES	MILLIMETERS
.00 = ±.01	.0 = ±.25
.000 = ±.004	.00 = ±.10
DRAWN: MJD	APPROVED: EMM
DATE: 01/01/14	DATE: 01/01/14

135X83X21

MODEL NO.
GFO-3-0825

SPLITTER 3 VIE

REV	DESCRIPTION	BY	DATE

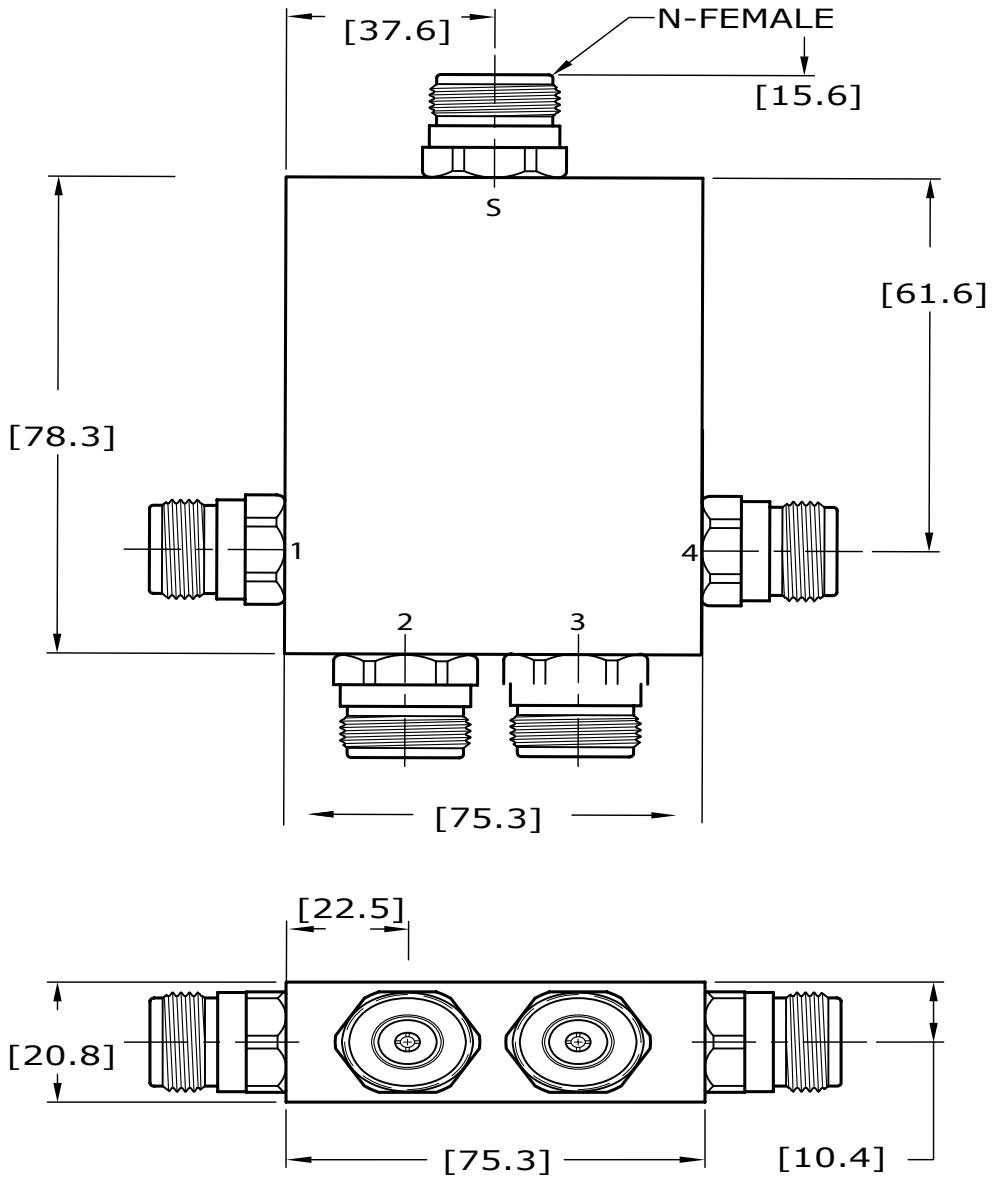

REV	DESCRIPTION	BY	DATE

TOLERANCES	
INCHES	MILLIMETERS
.00 = ±.01	.0 = ±.25
.000 = ±.004	.00 = ±.10
DRAWN: MJD	APPROVED: EMM
DATE: 01/01/14	DATE: 01/01/14

115X112X21

MODEL NO.
GFO-4-0825

SPLITTER 4 VIE